



Origin and early activities in acoustics at the Technical University of Denmark^{*}

Jens Holger Rindel^{1,*} and Claus Møller Petersen²

¹Odeon A/S, DTU Science Park, Diplomvej Bldg. 381, 2800 Kgs. Lyngby, Denmark

²Sweco Danmark A/S, Ørestads Boulevard 41, 2300 København S, Denmark

Received 17 September 2025, Accepted 26 January 2026

Abstract – Acoustic research and other activities at the Technical University of Denmark can be traced back to 1935, although it was not until 1966 that the university established an acoustical laboratory with new laboratory facilities of very high quality. The spark that initiated this development was the building of studios for the Danish Broadcasting 1931, that became an acoustical scandal and revealed the need for scientifically based knowledge on room acoustics and sound insulation. The rector of the Technical University, P.O. Pedersen, professor at the laboratory of tele-communication technique, started an acoustic research group in 1935, and he was the driving force in establishing a laboratory of sound technology in 1941. This was in the buildings of the Technical University, and some of the staff started to teach acoustics to the university students. P.O. Pedersen picked three young engineers for the acoustics research group: Vilhelm Jordan, Per Brüel, and Fritz Ingerslev. All three became of substantial importance for the development of acoustics in Denmark and worldwide; Jordan in concert hall acoustics, Brüel by establishing the B&K company, and Ingerslev as a professor at the university and a driving force in international cooperation (ICA, I-INCE) and standardization (ISO).

Keywords. Laboratory facilities, Scale models, Room acoustics, Noise

1 Great inventions and broadcasting

1.1 The telegraphone

Acoustics in Denmark started very early with some exciting inventions. Already in 1898 technician Valdemar Poulsen (1869–1942) invented the Telegraphone [2] a magnetic wire recorder, which became the forerunner of the tape recorder, see Figure 1. The suggested application reads in the patent (translated from Danish):

The telegraphone can be used locally, but is particularly suitable for distance phonographing, i.e. recording, storing and reproducing speech from an ordinary telephone set, as the telegraphone can replace the receiving telephone in the absence of the receiver.

At the world exhibition 1900 in Paris, Valdemar Poulsen got the chance to record the voice of Emperor Franz Josef of Austria. This is believed to be the oldest surviving magnetic audio recording¹.

An alternative construction of the telegraphone is shown in the patent description, see Figure 2. Here the magnet is fixed and the steel wire (l) is moved from one spool to another (k), exactly as in a tape recorder. A recording is made when the electric signal from a microphone is led to the electromagnet at m . This will cause a magnetisation of the steel wire. By a later play-back, the magnetised steel wire when moved past the electromagnet, will cause a varying electric current that can be let to a headphone.

1.2 The arc-transmitter

Only two years later in 1902, Valdemar Poulsen and his assistant engineer Peder Oluf Pedersen (1874–1941) invented the “Poulsen Arc Transmitter”. This was the world’s first radio transmitter and widely used in radio before the advent of the vacuum tube technology. It may be at this time that P.O. Pedersen became interested in acoustics and later launched the early development of acoustics in Denmark. A comprehensive description of these inventions and their early applications can be found in [3].

A lifelong friendship existed between the two men, and together they became the founders of electro technology, as well as acoustics, in Denmark, see Figure 3.

^{*} Parts of this article appeared in 2023 as a conference paper [1]. The present article has been significantly extended with figures and more detailed descriptions.

^{*} Corresponding author: jhr@odeon.dk

¹ https://www.youtube.com/watch?v=pzrB_pwi2TM.

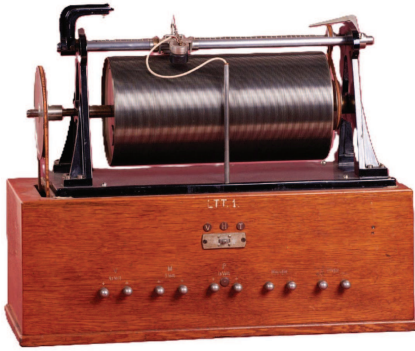

Figure 1. The telegraphone. Instrument number 1 at the Laboratory of Telegraphy and Telephony (LTT). Source: <https://www.danskeopfindelser.dk/opfindelse/telegrafon/>.

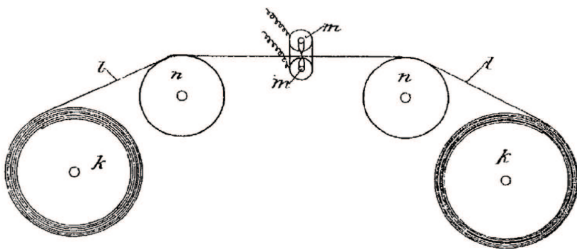

Figure 2. Alternative construction of the telegraphone. From the Danish patent No. 2653.

1.3 The professorship in low-current electro technology 1912

P.O. Pedersen had graduated as a master's in civil engineering, but through the cooperation with Valdemar Poulsen he became so interested in telecommunication that he picked up all available information about that by self-study. In 1909 he was employed at the Technical University² in Copenhagen in a newly established position as lecturer in telegraphy, telephony, and radio technology. In 1912 he was called to be a professor in the same field. This is believed to be the world's first university Chair in low-current electro technology. Later, P.O. Pedersen became the rector of the Technical University (1933–1941).

Among the six students on the first course on low-current technology were Arnold Poulsen and Axel Petersen, who later invented a sound film system, in which sound was recorded on a separate filmstrip running in parallel with the image reel, patent 1923.

1.4 The acoustical scandal 1931

The Danish Radio was established in 1925 and had from the beginning a small orchestra for broadcasting of live music. However, there was a need for new and better

² In Danish, *Polyteknisk Lærestalt* founded 1829 by H.C. Ørsted. The name was changed to *Danmarks tekniske Højskole* (DTH) in 1933 and to *Danmarks tekniske Universitet* (DTU) in 1994.



Figure 3. Double portrait of Valdemar Poulsen (left) and P.O. Pedersen (right) painted by Knud Larsen 1915.

studio facilities, and in 1931 such new radio studios were built in combination with a new stage for the Royal Theatre in Copenhagen. At this time there was little knowledge about acoustics, and an Austrian chemical engineer, Valdemar Oelsner, was engaged as he claimed to be an expert in acoustics. This was a great mistake. The sound insulation between the studios and the new theatre was insufficient, but more seriously, the main music studio was designed with hard walls in the lower part and sound absorption in the upper part, which resulted in a pronounced flutter echo and strong tonal coloration. Oelsner claimed that this was perfect, and that only few acousticians in the world had understood the importance of a reverberation time that varies strongly with frequency [4]. Acoustically, the new studio was a scandal; Oelsner was dismissed from the project, and the case was reported publicly in newspapers and went on for several years, all the way to the High Court. This event was the spark that triggered very efficiently the awareness of acoustics in Denmark.

2 Early acoustic research (1935–1953)

2.1 The first five years at LTT

The acoustical fiasco of the radio studios affected P.O. Pedersen so much, that he decided to start acoustic research activities, hosted at his Laboratory of Telegraphy and Telephony (LTT). Among the young researchers, that he employed for the work, were three men that became of decisive importance for the development of acoustics in Denmark:

- Vilhelm Lassen Jordan (1909–1982).
- Fritz Ingerslev (1912–1994).
- Per V. Brüel (1915–2015).

P.O. Pedersen published a report on the acoustical investigations 1935–1940 in the Laboratory of Telegraphy and Telephony (LTT) of the Technical University in Copenhagen [5]. The described activities were:



Figure 4. Reverberation chamber, built around 1935–40, 96 m³. The two persons are Ole Juhl Pedersen (left) and Jørgen Kristensen (right).

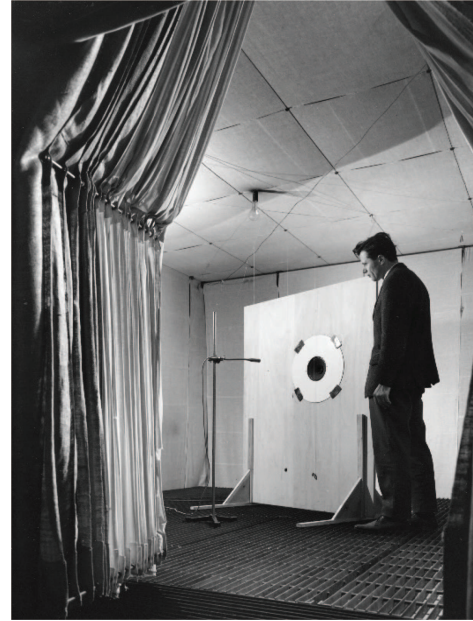

Figure 5. The anechoic chamber, built around 1935–40, 37 m³ free volume. The person is Jørgen Kristensen.

- Three original apparatus for the measurement of small vibrations in solid structures (constructions by Per V. Brüel).
- The new acoustical rooms of the laboratory.
- Four types of tube apparatus for the measurement of sound absorption at normal incidence covering the frequency range from 30 Hz to 20 000 Hz.
- The use of volume-resonators (Helmholtz-resonators) in room acoustics, and the practical application of such resonators to the acoustical regulation of a recently built auditorium.
- Room acoustical investigations in the scale 1/5 to 1/10 by means of the Poulsen-Telegraphone (Vilhelm L. Jordan).

The special laboratory rooms were two reverberant rooms (6*4*4) m³ for measurement of airborne sound insulation of walls, see [Figure 4](#), and one additional room (3*3*3) m³ for measurement of impact sound insulation of floors. A small anechoic chamber was also built, see [Figure 5](#). All surfaces of the anechoic chamber were covered with 19 layers of tissue, in total 84 cm thick. The free volume in the chamber had dimensions (4.14 * 3.70 * 2.40) m³.

2.2 Jordan's early experiments with scale models

The idea of using scale models for room acoustic studies came from Germany, where Spandöck had used an Edison phonograph with wax drum to convert the sound from the natural frequency range into the five times higher frequencies in a 1:5 scale model, see [Figure 6](#).

Jordan improved the technique by applying magnetic detection to a steel band in a Poulsen telegraphone. For Jordan's listening experiments were used speech or singing from a gramophone record. With a tape speed

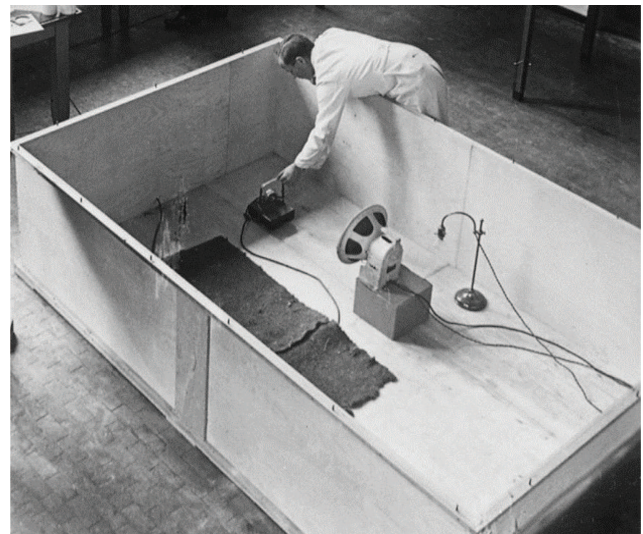

Figure 6. V.L. Jordan with the room acoustic scale model applied for auralization, around 1938.

of 3 m/s, a sequence of 20 s was recorded on the telegraphone. Then the sound was played in the model room at a band speed of 15 m/s; at the same time, the tape was erased and the sound from a crystal microphone in the model room was recorded instead, see [Figure 7](#).

As a sound source was used a crystal speaker or a small dynamic speaker, which allowed a frequency range up to 15 000 Hz equal to 3000 Hz in full scale. This was a great improvement compared to Spandöck's experiments. However, there were problems with linear distortion and limited dynamics due to the rather high noise level of the telegraphone recordings. Jordan [7, p. 110] mentions the results of the listening experiments thus:

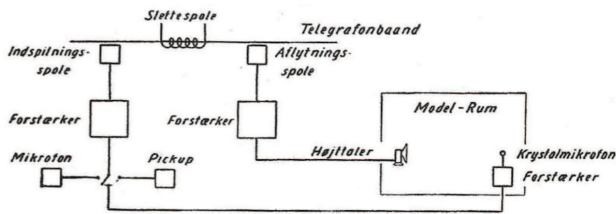

Figure 7. Diagram on the method for auralization in a scale model applied by V.L. Jordan. Adapted from [7, Fig. 49].

“In the untreated, weakly damped model, a very pronounced room effect is observed. Speech becomes completely incomprehensible, and the impression of the reproduced sound creates the illusion of a great space. Solo singing sounds like choral singing”.

It was concluded that the method could hardly be used for finer analyses. The main issues with the technique were electric noise in the microphone and too narrow usable frequency range. It was not until the 1990s that the idea of auralization was again taken up with greater success in connection with room acoustic computer models, see Section 4.7.

2.3 The Acoustical Laboratory 1941

P.O. Pedersen became director of the Technical University in 1922 and from 1933 he was rector of the same. In 1937 he was involved in the establishment of the Academy of Technical Sciences³, which was a kind of umbrella organization for various technical institutes that should provide testing and other kinds of assistance to the Danish industry and authorities. This was hard times for the country economically, and the only possibility for expanding the activities at the technical university was massive financial contributions from the Danish industry. P.O. Pedersen succeeded with this, and one argument was, that Denmark has no raw materials, so instead it was important to increase the skills, both in knowledge and production.

One of the first ATV institutes was an Acoustical Laboratory⁴ established 1941. This laboratory was hosted at the Technical University, and directly related to LTT. The scientific staff of the institute should also teach acoustics to the students at the university. Fritz Ingerslev became the head of the Acoustical Laboratory from the start in 1941. The acoustical activities in the following six years are described in a report [6] under the following headlines:

- Descriptions of the laboratories.
- Sound pressure, loudness, and frequency analysis of airborne sound.
- Mechanical vibrations.
- Reverberation time.
- Sound distribution.

³ In Danish, *Akademiet for de tekniske Videnskaber* (ATV).

⁴ In Danish, *Lydteknisk Laboratorium* (LL).

- Sound absorption coefficient measured by the tube- and the room-method.
- Sound insulation against airborne sound.
- Attenuation of impact sound.
- Electroacoustic measurements.
- Annex: Short description of the electrical measurement apparatus.

The work on sound absorption led to two doctoral theses⁵, one by V.L. Jordan [7] and another one by P.V. Brüel [8].

Concerning impact sound measurements, a tapping machine was constructed in the laboratory in agreement with existing American and German standards. Measurements were made in the unit of phon, using a sound level meter with weighting curve B.

Asger Kjerbye Nielsen had been working in the laboratory with resonators and theoretical models for slits and holes. He made a doctoral thesis on the reciprocity method for measurement microphones [9].

The teaching activities of the laboratory were directed towards students in building technology as well as in electro technology. Ingerslev became associate professor at LTT in 1943, and he wrote the first textbook on building acoustics in 1944, published five years later [10].

2.4 Concert hall acoustics as a spin-off

By the intervention of P.O. Pedersen, V.L. Jordan continued working with full scale concert hall acoustics in the concert hall (Studio 1) that was being built for the Danish Radio 1940–1945. Especially the acoustical connection between stage and auditorium had his attention. After 1945 he started as a consultant, and the first project was a new concert hall for the Tivoli Gardens in Copenhagen (1950–1956).

The cooperation with the architect Jørn Utzon on the famous Sydney Opera House is one of the first major examples of a modern concert hall, where the basic design and many details have been radically influenced through acoustic studies in scale models [11, p. 100]. In the opera hall, work was done on the balance between measurements of early reverberation⁵ on stage and in the hall, and the balance between a sound source on stage and in the orchestra pit. It was a very lengthy project, starting after the architectural competition in 1957 and continuing until the opening of the opera house in 1973. The architect changed the project several times, and four quite different designs of the concert hall were tested in 1:10 scale models.

During these years, there was a significant development of the acoustic measuring technique with better spark source, better and much smaller microphones, and the telegraphophone was replaced by the tape recorder with magnetic tape. Equally important was the parallel development of room acoustic parameters and criteria for objective assessment of concert hall acoustics, and here

⁵ Forerunners of the early decay time (EDT).



Figure 8. Fritz Ingerslev in his office around 1960. The portrait on the wall is of Valdemar Poulsen, painted 1940.

V.L. Jordan contributed actively: Rise Time 1959, Steepness 1965, Inversion Index 1968, Early Decay Time 1969, Room Response 1976.

Due to the very long process in Sydney, experience was gathered in the meantime from several other large projects, where Jordan used and further developed the modeling technique. One of these projects was the Metropolitan Opera House in New York with 3800 seats, designed in the years 1959–1966. For several decades, V.L. Jordan and his son, Niels Jordan (1941–2017) did the acoustics of many concert halls all over the world, in many cases using scale models for the acoustical analysis of the design.

3 The noise professor (1954–1982)

3.1 International cooperation

Fritz Ingerslev was a fiery soul and soon he took up the fight against noise, and this became his lifelong mission. In 1953 he defended his doctoral thesis [12] (on loudspeakers) and the following year he became professor in low-current electronics at the LTT department, see Figure 8. Still, he continued as head of the Acoustical Laboratory.

Ingerslev's international engagement was pronounced, and in 1954 he was the driving force in creating the Nordic Acoustic Association as a forum for connection between acousticians in the Nordic countries. However, only Finland and Sweden had already an acoustical society, so it was a little premature. Norway and Denmark established their national acoustical societies in 1956.

Already in 1951, Ingerslev became a member of the board of International Commission for Acoustics (ICA), a position that he kept until 1969. The main activity of this commission was to arrange international conferences on acoustics, which should be every third year. So, Ingerslev became the chairman of the fourth ICA in Copenhagen

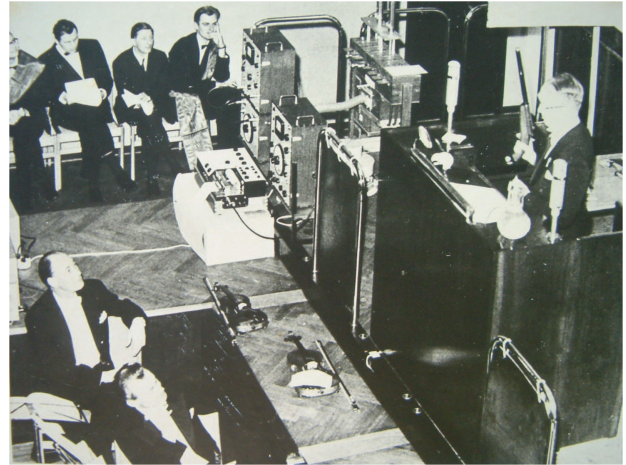

Figure 9. Fritz Ingerslev giving a distinguished lecture at the annual celebration of the Technical University 1960. The gun was used to demonstrate measurement of reverberation time.

1962, a great success with 1200 participants, 300 presentations in nine parallel sessions and 15 invited plenary lectures. One of the challenges – long before telefaxing and internet – was a demand from UNESCO that there should be three official languages: English, German and French, and the presentations could be given in any of these languages.

3.2 The Acoustics Laboratory 1963

Since 1957 Ingerslev was a member of a committee at the technical university that should outline the future needs of the electrical engineering sector. The background was that the buildings in central Copenhagen had become insufficient and without possibilities for further expansion. In 1960 it should be decided to move the technical university to a new campus area North of Copenhagen. Acoustical facilities of the highest possible quality were included in the plans. It was probably of decisive importance that Ingerslev gave a distinguished lecture on acoustics at an annual celebration at the technical university, attended by people with good connections to politicians with influence on the necessary decisions, see Figure 9. His passionate talk must have been very convincing.

The new acoustic facilities included two anechoic chambers (1000 m³ and 60 m³), see Figure 10, and four reverberation chambers (around 240 m³), see Figure 11, for the measurement of acoustical properties of building materials and constructions [13].

In connection with the movement to the new campus, the technical university established 1963 a new department, the Acoustics Laboratory⁶. The older ATV-institute, the Acoustical Laboratory, moved into the same building, and some of the staff were transferred to the new

⁶ In Danish, *Laboratoriet for akustik* (LA). The name was changed in 1995 to Department of Acoustic Technology.



Figure 10. The anechoic room built 1963, 1000 m³ free volume. The person is Peter Koefoed Møller.



Figure 11. One of the reverberation rooms built 1963, 240 m³.

university department. In the following years, Ingerslev was the head of both laboratories (LA and LL) sharing the facilities. While the new LA should do teaching and research, the working field of LL was to do measurements and give advice to the government and the industry.

3.3 ISO and IINCE

In 1961 professor Ingerslev became aware of the possibilities associated with international standardization, and he asked the Danish Standardization Organization (DS) to establish a formal membership of the technical committee ISO/TC 43 Acoustics. In the following years, several working groups were established with Ingerslev as convener and new standards were made concerning measurement of noise from vehicles and airplanes. Two subcommittees were made in 1968, SC 1 Noise and SC 2 Building Acoustics, and Ingerslev was appointed chairman of SC 1 with secretariat hosted by Danish Standard. Shortly after the same happened with the secretariat of

the general acoustics committee TC 43. This development says something about Ingerslev; how dedicated and efficient he was, and highly respected among international colleagues.

The Institute of Noise Control Engineering (INCE) was established in the USA with the purpose of arranging meetings dealing with noise problems, and Ingerslev followed this initiative with great interest. The first Inter-Noise conference was held in the USA 1972 and already next year, the second Inter-Noise conference was held in Denmark with Ingerslev as chairman. After this success, he became co-founder and chairman (1974–1988) of the International Institute of Noise Control Engineering (I-INCE), coordinating the Inter-Noise conferences held all over the world every year.

The subtitle of the second Inter-Noise conference was “Noise is a sneaking poison”. This was meant to emphasize the seriousness of the fight against noise in workplaces, in homes and in the environment. Ingerslev used the press to spread information about the event and to pay attention to noise problems among engineers and politicians; he wanted to wake them up!

A special issue of the Noise Control Engineering Journal was published in 1989 “in honor of Professor Fritz Ingerslev upon the completion of his tenure as the Charter President of the International INCE” [14].

3.4 The fight against traffic noise

Traffic noise came in the focus in the 1970s, and through his use of the press, Ingerslev became generally known as the noise-professor. When the government established a ministry of the environment, he arranged a meeting with the minister to explain the importance of noise. The press was informed about the meeting, and the newspapers could bring an article with a photo of the noise professor meeting the minister. Ingerslev was a master of “political acoustics”.

So, even politicians were listening to Ingerslev when he had something to say. One example is the plan for a four-lane motorway that should lead the traffic into the center of Copenhagen along the lakes surrounding the old city center; however, Ingerslev’s protests managed to stop this.

Founding was raised for an ambitious PhD project for the psychologist Else Relster, who should study the effects of traffic noise with Ingerslev as supervisor. He involved the Acoustical Laboratory to do measurements of noise exposure of dwellings that were selected to be either with high or low traffic noise levels. Else Relster did 960 interviews and was able to establish a dose-response connection showing the decrease of wellbeing with noise levels exceeding 55 dB⁷. The measurements and interviews were made under ideal conditions as early as 1972, i.e., before it became common to apply special sound insulating windows in areas with high noise exposure.

⁷ $L_{A,eq,24h}$ in free field.

3.5 The vision for the Acoustics Laboratory

From 1974 to 2008, the Acoustics Laboratory has made annual reports⁸ describing the activities in teaching and research. In the first years, the acoustical areas in which the laboratory had research and teaching, were outlined as follows:

- Aeroacoustics (outdoor sound propagation).
- Fundamental acoustics and measurement technique.
- Bioacoustics, physiological and psychological acoustics in relation to humans and animals.
- Building acoustics.
- Electroacoustics.
- Mechanical vibrations.
- Musical acoustics (musical instruments).
- Room acoustics.
- Noise.

In addition, was mentioned ultrasound and underwater acoustics as areas in which the laboratory was not active. Some of the research activities were in close cooperation with the Acoustical Laboratory under ATV, which was also headed by Ingerslev and located in the same building.

For historical reasons, the Acoustics Laboratory was established under the electrotechnical faculty, see [Section 2.1](#). However, from the very beginning it was clear that research and teaching activities should include the relevant areas of building engineering and mechanical engineering.

Thus, in 1975 the faculty of building engineering agreed to establish both a lecturer position and a professorship in building acoustics, assigned to the Acoustics Laboratory. Jens Holger Rindel was employed to teach building acoustics, but when professor Ingerslev was asked to be a member of the committee that should evaluate the applicants for the professorship, he refused, because he considered applying himself. Thus, the position was never announced, and Ingerslev was called to be professor in building acoustics. Then, what should happen with Ingerslev's former professorship in low-current electro technology? It was clear that it should be within acoustics, but it turned out to be more complicated than anyone had expected. Eventually, Leif Bjørnø (1937–2015) became the new professor in acoustics in 1978. He had a background in mechanical engineering, and he was particularly interested in ultrasound and underwater acoustics. Thus, ideally this would complete the vision of covering all aspects of acoustics. However, the cooperation with the other members of the academic staff in the Acoustics Laboratory was difficult, and gradually became worse. In 1982, professor Bjørnø's research group for Industrial Acoustics moved to another department under the faculty of mechanical engineering. He left DTU in 2000.

When Fritz Ingerslev retired in 1982, his professorship in building acoustics was not opened for a successor. However, the field of building acoustics was led by Jens

Holger Rindel, who was promoted to professor (docent) in 1990.

4 Research and cooperation

4.1 Measurement microphones and metrology

Microphone calibration was an important activity since the early work of Asger Kjerbye Nielsen [9]. At the Acoustics Laboratory this was headed by Knud Rasmussen, who managed to get several international grants and projects under the European Community Bureau of Reference (BCR) and the European Metrology Networks (EUROMET). The Danish primary laboratory of acoustics (DPLA) was established 1989 in collaboration with B&K, responsible for maintaining and disseminating the basic unit of sound pressure (the pascal) and acceleration (m/s^2) in Denmark.

4.2 Digital signal processing

From 1972 the field of digital signal procession in relation to acoustical applications was taught by Simon Boel Pedersen and Peter Koefoed Møller. This field became very popular among the students. This very successful research group moved in 1987 from acoustics to join another department with a focus on digital signal procession within the Institute of Electronics. One example of practical applications of digital signal procession is a system for detecting leakage in pipes, developed by P.K. Møller in cooperation with the company Caltronic ApS.

4.3 Outdoor sound propagation

Sound propagation over terrain was a research field of great importance for calculations models in relation to traffic noise and noise from industrial plants. At the Acoustics Laboratory this was taken up by Karsten Bo Rasmussen, who did scale model experiments for verification of advanced theoretical models. He defended his Dr. Techn. Thesis on this subject in 1991. However, in 2000 he left DTU to join the research center for hearing aids at Oticon.

4.4 Psychoacoustics and hearing aids

Since the establishment of the Acoustics Laboratory in 1963, Ole Juhl Pedersen was a driving force in the field of acoustic communication. His teaching together with Torben Poulsen has formed the basis of several psychoacoustical and audiological MSc- and PhD-projects as well as national and large international research projects often in cooperation with industry. Among them were the audiological ODIN project, a research cooperation between the three large Danish hearing aid companies. Without the industry that employed all these candidates, psychoacoustics would not have had such success – and vice versa.

⁸ Publications from the Acoustics Laboratory, Technical University of Denmark (DTU), ISSN 0105-2853.



Figure 12. Set-up in the large anechoic chamber for the Archimedes project in 1988.

4.5 Loudspeakers

The good acoustic research facilities at DTU were basis for the EU-project Archimedes under the framework of EUREKA (with Bang & Olufsen in Denmark and KEF in England). This was on the sensation of sound quality of loudspeakers. This involved room simulations in the anechoic chamber, see [Figure 12](#), and the building of a new IEC listening room in 1989.

The following “Lo-dist” project was on audibility of distortion in loudspeakers. Optimal acoustic quality was also the goal for another set of scientific investigations on perceived sound from loudspeakers made by B&O (Søren Bech) in cooperation with Danish and international universities. These projects ended up both with inventions and new state-of-the-art loudspeakers.

4.6 Concert halls and musicians

Architectural acoustics and in particular the field of room acoustics was given more weight after 1975. The acoustics of concert halls from the musicians’ point of view became one of the new research areas, with pioneering work on stage acoustics by Anders Christian Gade (1982) and Graham Naylor (1987). The laboratory setup for the experiments with two musicians playing together was quite extreme, including two anechoic chambers in different buildings, one reverberation chamber (in another building) and a PDP-8 computer (in a fourth building) to control the various sound signals to the musician while playing their instruments, see [Figure 13](#).

Measurement campaigns were made collecting acoustical parameters in concert hall, first in Denmark (1984) and later in some of the best halls in Europe (1989).

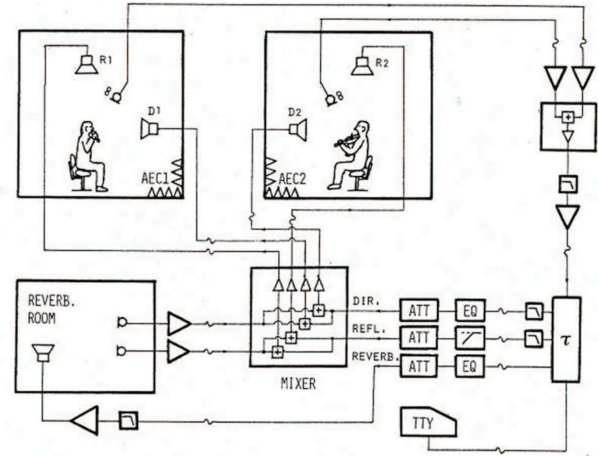

Figure 13. Setup for two musicians playing together involving two anechoic chambers, one reverberation room and a PDP 8 computer, Gade (1982).



Figure 14. Scale model 1:20 used for investigations on the old DR concert hall, 1988. Wall reflectors and a suspended reflector array were part of the refurbishment.

This research activity led to a project supported by the Danish Radio (DR), namely, to solve the acoustical problems in the DR concert hall from 1945, mentioned above in [Section 2.4](#). The problems were on the orchestra stage as the musicians could not hear each other while playing. After a couple of years with scale model investigations and full-scale experiments with the symphony orchestra, the concert hall could re-open in 1989 with significantly improved stage-acoustics including reflector panels designed in accordance with new research results, see [Figure 14](#).

4.7 Room simulation and auralization

Sound fields in rooms was one of the main research fields of Finn Jacobsen. In 1984 Rindel initiated the development of computer simulations of sound in rooms, with the vision to include auralization. With various external funding, the work was started with Asger Donovan, and



Figure 15. Auralization in 1993 using the M5000 from t.c.electronic in combination with the Odeon software. Claus Lynge Christensen (left) and Jens Holger Rindel (right). Photo: Nina Lemvig-Müller.

continued by Graham Naylor. The program was named ODEON and launched for commercial distribution in 1991.

The same year, an international symposium on room acoustic simulation and auralization was organized by Rindel, Naylor and Mendel Kleiner from Chalmers Technical University in Sweden [15]. This symposium stimulated the international cooperation with research groups within the field, especially in Sweden, Germany, France and Japan.

The work with the room acoustic simulation tool and auralization was continued with Claus Lynge Christensen. In 1993 it was made possible to do high-quality auralization by combining the room acoustic simulation results with a piece of hardware from the Danish company t.c.electronic, see Figure 15. In 1999 the auralization was taken one step further by convolution of the anechoic signal with a calculated binaural room impulse response (BRIR).

In the following years, the Odeon software became the basis for several related research projects headed by Rindel, including the spectacular EU-projects CHARISMA on Byzantine churches and Sinan's mosques (2000–2003) and ERATO on Roman theaters and odea (2003–2006). The connection between musical instruments and rooms was the topic of the EU project DOREMI and the first multi-source auralizations of a symphony orchestra were made with ODEON in 2005. In 2008, Rindel left the university, and the Odeon company moved to its own premises at the DTU Science Park, within walking distance from the acoustics laboratories.

4.8 Noise from machinery

Noise in ships, and structural noise from diesel engines were studied by John Ødegaard at DTU from 1972 using scale models (1:5).



Figure 16. Mogens Ohlrich with a scale model of a helicopter 1993.

This research field was continued by Mogens Ohlrich, and from a long list of projects can be mentioned noise from wind turbine towers (1985) and interior noise in helicopters (RHINO, 1995), see Figure 16. The EU project FANPAC was on noise from turbofan engines (1996).

5 The international perspective

5.1 Shift of focus from teaching to research

The first years after 1963, when the Acoustics Laboratory was established, the academic staff had a strong focus on teaching activities, and during the 70's and 80's the lecture notes for the various acoustic courses were constantly improved and brought to a high level of quality, although in Danish. Examples are the comprehensive lecture notes by Knud Rasmussen on mechanical and magnetic registration of sound [16, 17].

In these years, research at the Acoustics Laboratory was published in reports⁹, only. There was no tradition for publishing research results in the international scientific journals. However, around 1990 things changed because there was an increasing demand to the academic staff to publish in peer-reviewed journals, see Figure 17. Finn Jacobsen was particularly efficient in writing scientific papers for journals, which was inspiring for his colleagues. One example of his papers is reference [18]. Research papers from the Acoustics Laboratory can be found in the link, reference [19].

⁹ Reports from the Acoustics Laboratory, Technical University of Denmark (DTU), ISSN 0105-3027.

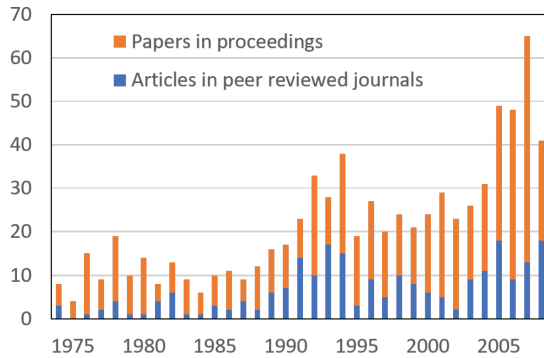

Figure 17. Number of scientific papers from the Acoustics Laboratory per year.

5.2 Visiting researchers

Around 1990 the approach to research became more international, and with various types of grants it was possible to receive or invite research fellows and other scientists for longer stays at the Acoustics Laboratory, see Figure 18. From 2001 this also included PhD students from foreign universities.

Severe budgetary problems for the university appeared in 1997, and 7% of academic staff at DTU had to leave. However, due to very favorable rating results, none of the academic staff at the Department of Acoustic Technology¹⁰ were affected. This year, the department received 77% of the total budget from industry and national and international grants.

In 1999 Jean-Dominique Polack was appointed professor in electroacoustics. However, only two years later he decided to leave and return to France, where he had his family. Although his wife was Danish, she was not willing to give up her job in Paris. No successor was appointed.

5.3 International MSc in Engineering Acoustics

A decreasing number of Danish engineering students was becoming a problem for DTU in 1998. At the same time the Department of Acoustic Technology experienced an increasing internationalization that called for lectures and lecture notes in English. A new international two-year MSc program in Engineering Acoustics was launched in 2000. From then on, all courses in acoustics were given in English because many students from abroad attended the courses. This turned out to be a great success, and the number of highly motivated foreign students in acoustics more than compensated for the lack of Danish engineering students at this time (half of the students on acoustics courses were from abroad in 2000). In this way, the section of Acoustic Technology avoided reductions in the scientific staff. The number of candidates finishing this international MSc program has increased to more than 40 per year in 2025.

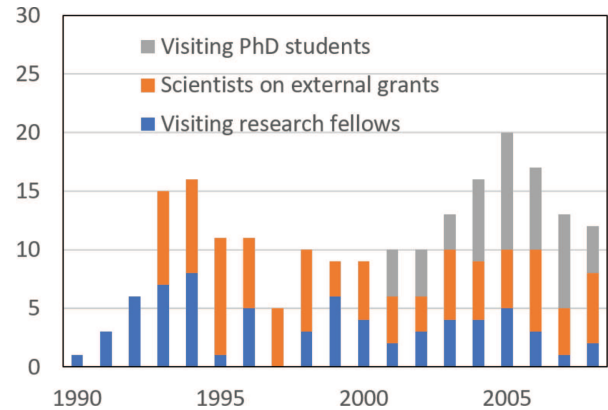

Figure 18. Number per year of visiting research fellows, scientists on external grants, and PhD students.

5.4 New structure of the university

A new structure of DTU in 2000 meant fewer but bigger departments. Department of Acoustic Technology (new name for the Acoustics Laboratory) became one of five sections in Ørsted-DTU, a big department of electro technology. In the annual report for the year 2000 is stated that a major challenge is facing the section of Acoustic Technology in the coming years:

Acoustic Technology shall have to redefine areas of excellence and converge toward a few specific areas where collaboration within the section, with industry, and with other institutions both in Denmark and abroad, can achieve critical mass.

It is not clear what is meant by critical mass, but obviously the former vision, that the department should cover all relevant aspects of acoustics, is no longer valid.

5.5 New research centers related to acoustics

Thanks to massive financial support from the Danish hearing aid industry, the acoustical activities have expanded immensely after 2000. In 2003 was established the Centre for Applied Hearing Research (CAHR). The purpose with CAHR includes promoting research and education on acoustical communication hearing impaired peoples' listening capabilities and the use of auditive models in hearing aids. Impressive results are achieved due to exchange of knowledge, where cooperation between common university research and industrial development goes hand in hand. In 2013 The Oticon Centre of Excellence for Hearing and Speech Sciences (CHESS) in which connection new research facilities has been built as extensions to the original laboratories. In 2014 the Centre for Acoustic-Mechanical Micro Systems (CAMM) was established, connected to the Acoustic Technology section under the Department of Electrical and Photonics Engineering.

¹⁰ New name for the Acoustics Laboratory.

Conflicts of interest

The first author, Jens Holger Rindel was employed by the company Odeon A/S. Jens Holger Rindel declares that the research was conducted in the absence of any commercial or financial relationships that could be construed as a potential conflict of interest.

Data availability statement

Data are available on request from the authors.

References

1. J.H. Rindel, C.M. Petersen: Origin and early activities in acoustics at the Technical University of Denmark, in: Proceedings of Forum Acusticum, 11–15 September 2023, Turin, Italy, 2023, pp. 763–770. DOI: [10.61782/fa.2023.0227](https://doi.org/10.61782/fa.2023.0227).
2. Danish patent No. 2653: Ingeniør Valdemar Poulsen, København. Telegrafon, 1899.
3. L. Bock: Buen og Gnisten. Pionererne fra radioens barndom (The Bow and the Spark. The pioneers of the early days of radio). Gyldendal, Copenhagen, 2017.
4. V. Oelsner: Det teknisk-videnskabelige grundlag for “Rumakustik og lydisolering”: System Oelsner (The technical and scientific basis of “Room acoustics and sound insulation”: System Oelsner). Hjorths Tryk, Copenhagen, 1935.
5. P.O. Pedersen: Lydtekniske Undersøgelser i Aarene 1935–40 i Den polytekniske Lærestalts Laboratorium for Telegraf og Telefoni (Sound Technical Investigations in the Years 1935–40 in the Polytechnic College’s Laboratory for Telegraphy and Telephony), The Academy of Technical Sciences, Copenhagen, 1940.
6. F. Ingerslev, A. Kjærbye Nielsen: Lydteknisk Laboratoriums Arbejde 1941–1946, Maaleapparater og Maalemetoder (The work of the Acoustical Laboratory 1941–1946, measuring devices and measurement methods). The Academy of Technical Sciences, Copenhagen, 1947.
7. V.L. Jordan: Elektroakustiske Undersøgelser af Materialer og Modeller (Electroacoustic Studies of Materials and Models). (Dr. Techn. Thesis). The Academy of Technical Sciences, Copenhagen, 1941.
8. P.V. Brüel: Rørmetodens Anvendelse i Akustiken (The application of the tube method in acoustics). (Dr. Techn. Thesis). The Academy of Technical Sciences, Copenhagen, 1945.
9. A. Kjærbye Nielsen: Mikrofonmålinger med særlig henblik på reciprocitetsmetoden (Microphone measurements with special reference to the reciprocity method). (Dr. Techn. Thesis). Copenhagen, 1949.
10. F. Ingerslev: Akustik, lærebog i bygningsakustik for ingeniører (Acoustics, Building Acoustics Textbook for Engineers). Teknisk forlag, 1949.
11. V.L. Jordan: Acoustical Design of Concert Halls and Theatres. Applied Science Publishers, London, 1980.
12. F. Ingerslev: Measurements of linear and non-linear distortion in electrodynamic loudspeakers. (Dr. Techn. Thesis). Copenhagen, 1953.
13. F. Ingerslev, O.J. Pedersen, P.K. Møller, J. Kristensen: New rooms for acoustic measurements at the Danish Technical University. *Acustica* 19, 4 (1967/1968) 185–199.
14. W.W. Lang: In honor of Fritz Ingerslev (Editorial). *Noise Control Engineering Journal* 32, 2 (1989) 50–52.
15. G.M. Naylor: Guest editorial. *Applied Acoustics* 38 (1993) 89–92.
16. K. Rasmussen: Mekanisk registrering (Mechanical registration), lecture note 2602. The Acoustics Laboratory, Technical University of Denmark (DTU), 1974/1986.
17. K. Rasmussen: Magnetisk registrering (Magnetic registration), lecture note 2601. The Acoustics Laboratory, Technical University of Denmark (DTU), 1977/1982.
18. F. Jacobsen: Sound power determination using the intensity technique in the presence of diffuse background noise. *Journal of Sound and Vibration* 159, 2 (1992) 353–371.
19. Research papers from the Acoustics Laboratory: <https://orbit.dtu.dk/en/organisations/acoustic-technology-2/publications/>.

Cite this article as: Rindel J.H. & Petersen C.M. 2026. Origin and early activities in acoustics at the Technical University of Denmark. *Acta Acustica*, 10, 13. <https://doi.org/10.1051/aacus/2026010>.